

# OSA4

## LED Adjustable Sconce

### Product Description

The OSA4 LED Adjustable Sconce features next-generation design with Selectable CCT/ Wattage models. With efficiencies up to 138 lumens per watt, the OSA provides optimal light in a compact, adjustable design. Using a separable hinged backplate, the OSA is easy to install on walls or directly to a J-Box, and is adjustable from 0 to 90-degrees. An internal switch offers the ability to adjust the Wattage to low, medium, or high setting and to select the CCT (3000K/4000K/5000K). It is an economical and efficient replacement for a traditional wall pack and is ideal for accent or general purpose exterior lighting.

#### Construction

- Die-cast aluminum housing
- (4) ½" knockouts for conduit feed or sensors
- Tool-less separable hinged backplate
- Stainless steel hardware
- UV-stabilized powder coat finish

#### Optical System

- Clear injection-molded acrylic lens
- UV- and fire-resistant lens
- Selectable CCTs (3000/4000/5000K) with >70 CRI

#### Electrical

- Selectable power levels: (30/20/12W), (50/40/30W) and (80/70/60W)
- Operating temperature rating of -40° to 122°F (-40°C to 50°C)
- Input voltage of 120-277VAC
- 0-10VDC dimming
- Photocell Standard (Can be disabled in field)

#### Mounting and installation

- Separable hinged backplate to allow for easy mounting
- Fixture mounts directly to J-Boxes and walls with screws
- Adjustable range of 0° to 90°
- For installations where power surge may be possible, NICOR recommends installing additional surge protection at the electrical distribution panel

#### Listings

- cULus 1598 listed for wet locations, IP65 Rated
- LM-79, LM-80 testing performed in accordance with IESNA standards
- Meets FCC Part 15, Subpart B, Class B standards for conducted and radiated emissions
- RoHS Compliant
- TM-21 Reported L70(9k) life >54,000 hours
- DLC 5.1 Standard listed

#### Warranty

- 5-year limited system warranty standard
- Warranty does not cover product failure due to an overvoltage event (power surge)

Project

Catalog

Type

Date



## OSA4 LED Adjustable Sconce Wattage Selectable CCT Selectable



# Ordering

## Ordering Information

Example: OSA4050SUNVSBZ

Series	Version	Wattage Selectable	Voltage	CCTs Selectable	Finish	Controls
OSA	4	030S (30/25/12W)	UNV (120-277)	S (3/4/5000K)	BZ (Bronze)	_(Blank) <sup>1</sup>
		050S (50/40/30W)			WH (White)	
		080S (80/70/60W)				

Specifications and dimensions subject to change without notice.

1. Photocell is a standard feature of OSA4

## Performance Data

Performance Data						
Model Number	Wattage Setting	CCT	Lumens	Watts	Lumens/Watt	BUG Rating
OSA4030	12	3000	1411		118.6	B2-U2-G1
		4000	1512	11.9	127.1	
		5000	1497		125.8	
	25	3000	2962		118	
		4000	3176	25.1	126.5	
		5000	3143		125.2	
	30	3000	3527		120.0	
		4000	3781	29.4	128.6	
		5000	3742		127.3	
OSA4050	30	3000	3788		125.8	B2-U2-G1
		4000	4091	30.1	135.9	
		5000	3955		132.7	
	40	3000	4925		123.2	
		4000	5319	40.2	132.3	
		5000	5142		127.9	
	50	3000	6314		123.8	
		4000	6819	51.0	133.7	
		5000	6592		129.3	
OSA4080	60	3000	7713		128.3	B2-U2-G1
		4000	8307	60.1	138.5	
		5000	8107		135.1	
	70	3000	8999		128.9	
		4000	9692	69.8	138.4	
		5000	9574		136.7	
	80	3000	10284		128.6	
		4000	11076	80.2	138.5	
		5000	10942		136.7	

### Recommended 0-10VDC Dimmers\*

Lutron NTSTV  
 Lutron DVSTV  
 Cooper SF10P  
 Legrand RH4FBL3PW

\*Not a complete list. Check compatibility before installation.

# Photometric Data

## OSA4 30W 3000K

Input Voltage (VAC)	120
System Level Power (W)	29.4
120V Current (A)	0.25
277V Current (A)	0.11
Delivered Lumens (Lm)	3527
System Efficacy (Lm/W)	120
Correlated Color Temp (K)	2994
Color Rendering Index (CRI)	72
Horizontal Beam Angle (°)	106.7
Vertical Beam Angle (°)	83.1
Spacing Criteria (0-180)	1.54
Spacing Criteria (90-270)	1.26
BUG Rating	B2-U2-G1

## Intensity Summary (Candle Power)

Angle	Mean CP
0	1571
5	1616
15	1676
25	1672
35	1568
45	1386
55	1029
65	392
75	90
85	2
90	0

## Zonal Lumen Summary

Zone	Lumens	% of Luminaire
0-30	1178	33.4%
0-40	1861	52.8%
0-60	3064	86.9%
0-90	3527	100%
90-180	0	0%
0-180	3527	100%

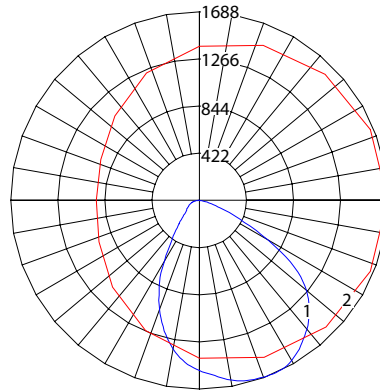

1 - Vertical Plane Through Horizontal Angle  
2 - Horizontal Cone Through Vertical Angle

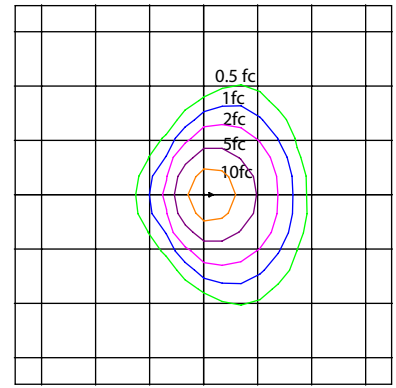

10' Mounting Height (1 square = 100 sq ft)

## CCT Data Multiplier

4000K	1.027
5000K	1.061

## OSA4 50W 3000K

Input Voltage (VAC)	120
System Level Power (W)	51.0
120V Current (A)	0.43
277V Current (A)	0.19
Delivered Lumens (Lm)	6314
System Efficacy (Lm/W)	123.8
Correlated Color Temp (K)	2935
Color Rendering Index (CRI)	73
Horizontal Beam Angle (°)	106.5
Vertical Beam Angle (°)	83.3
Spacing Criteria (0-180)	1.56
Spacing Criteria (90-270)	1.26
BUG Rating	B2-U2-G1

## Intensity Summary (Candle Power)

Angle	Mean CP
0	2723
5	2819
15	2962
25	2959
35	2794
45	2471
55	1940
65	831
75	199
85	4
90	0

## Zonal Lumen Summary

Zone	Lumens	% of Luminaire
0-30	2069	32.8%
0-40	3284	52%
0-60	5429	86%
0-90	6314	100%
90-180	0	0%
0-180	6314	100%

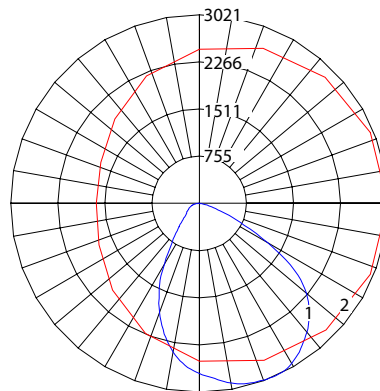

1 - Vertical Plane Through Horizontal Angle  
2 - Horizontal Cone Through Vertical Angle

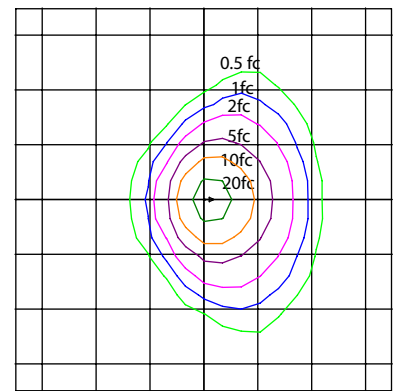

10' Mounting Height (1 square = 100 sq ft)

## CCT Data Multiplier

4000K	1.080
5000K	1.044

Fixture tested per LM-79-08. Photometric data is of the performance of a representative fixture. Results may vary in the field.

## OSA4 80W 3000K

Input Voltage (VAC)	120
System Level Power (W)	80.1
120V Current (A)	0.67
277V Current (A)	0.32
Delivered Lumens (Lm)	10284
System Efficacy (Lm/W)	128.4
Correlated Color Temp (K)	2932
Color Rendering Index (CRI)	73
Horizontal Beam Angle (°)	108.9
Vertical Beam Angle (°)	85.7
Spacing Criteria (0-180)	1.50
Spacing Criteria (90-270)	1.26
BUG Rating	B2-U2-G1

## Intensity Summary (Candle Power)

Angle	Mean CP
0	4521
5	4580
15	4703
25	4670
35	4438
45	3891
55	2915
65	1212
75	307
85	8
90	0

## Zonal Lumen Summary

Zone	Lumens	% of Luminaire
0-30	3426	33.3%
0-40	5430	52.8%
0-60	8887	86.4%
0-90	10284	100%
90-180	0	0%
0-180	10284	100%

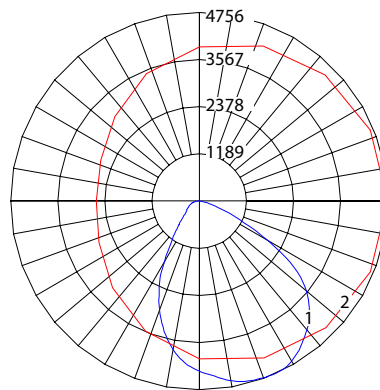

1 - Vertical Plane Through Horizontal Angle  
2 - Horizontal Cone Through Vertical Angle

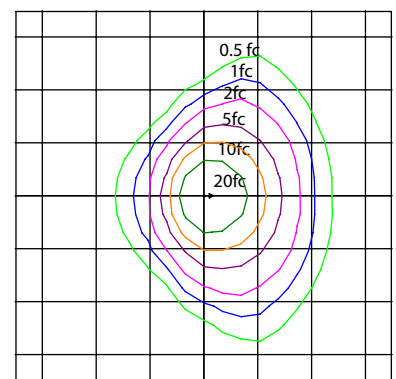

10' Mounting Height (1 square = 100 sq ft)

## CCT Data Multiplier

4000K	1.077
5000K	1.050

Fixture tested per LM-79-08. Photometric data is of the performance of a representative fixture. Results may vary in the field.

# Dimensions

## FIXTURE

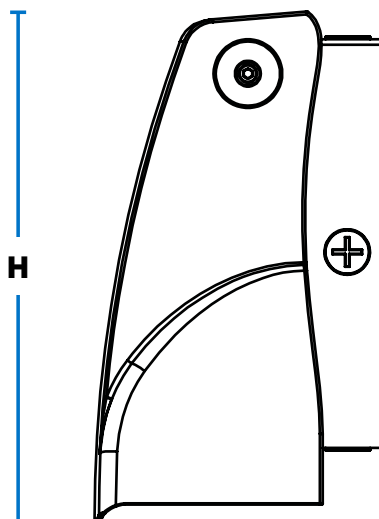
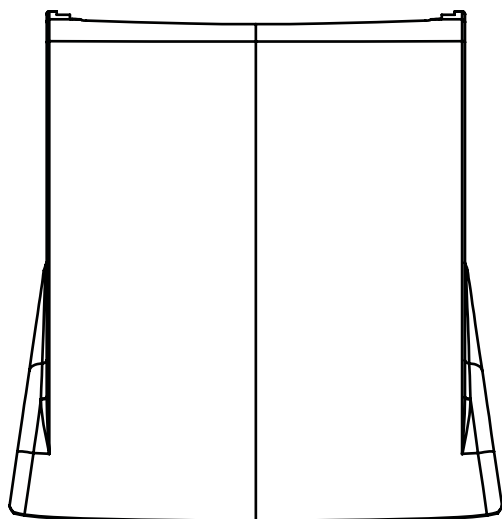

## DRIVER BOX

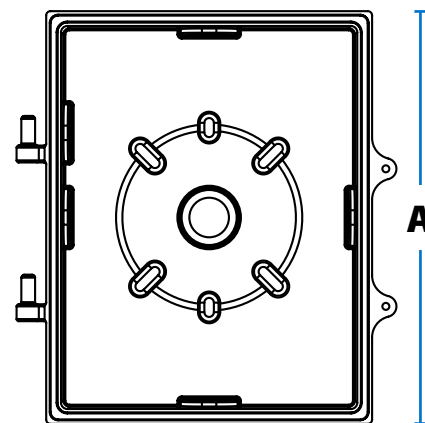

	30W	50W	80W
<b>Fixture Length (L)</b>	7.2 in (182 mm)	8.4 in (213 mm)	8.4 in (213 mm)
<b>Fixture Width (W)</b>	4.6 in (116 mm)	5.0 in (127 mm)	5.0 in (127 mm)
<b>Fixture Height (H)</b>	7.4 in (188 mm)	9.1 in (230 mm)	9.1 in (230 mm)
<b>Fixture Weight</b>	3.0 lbs(1.36 Kg)	4.4 lbs (2 Kg)	4.9 lbs (2.2 Kg)
<b>Fixture Driver Box (A)</b>	5.6 in (142 mm)	7.1 in (180 mm)	7.1 in (180 mm)
<b>Fixture Driver Box (B)</b>	4.6 in (102 mm)	5.6 in (142 mm)	5.6 in (142 mm)
<b>Fixture Driver Box (C)</b>	6.3 in (160 mm)	7.5 in (191 mm)	7.5 in (191 mm)

This device complies with part 15 of the FCC Rules. Operation is subject to the following two conditions: (1) This device may not cause harmful interference, and (2) this device must accept any interference received, including interference that may cause undesired operation.

NOTE: This equipment has been tested and found to comply with the limits for a Class B digital device, pursuant to part 15 of the FCC Rules. These limits are designed to provide reasonable protection against harmful interference in a residential installation. This equipment generates, uses and can radiate radio frequency energy and, if not installed and used in accordance with the instructions, may cause harmful interference to radio communications. However, there is no guarantee that interference will not occur in a particular installation. If this equipment does cause harmful interference to radio or television reception, which can be determined by turning the equipment off and on, the user is encouraged to try to correct the interference by one or more of the following measures:

- Reorient or relocate the receiving antenna.
- Increase the separation between the equipment and receiver.
- Connect the equipment into an outlet on a circuit different from that to which the receiver is connected.
- Consult the dealer or an experienced radio/TV technician for help.